

HB Series Control Valve with Pneumatic Actuator

Models	HB Series
Service	Steam, Air, Water
Sizes	1/2", 3/4", 1", 1 1/2", 2"
Connections	NPT, 150# FLG, 300# FLG
Body Material	316 Stainless Steel
Plug and Seat Material	Stainless Steel
PMA Max. Operating Pressure	720 PSIG @ 100°F
TMA Max. Operating Temperature	450°F @ 497 PSIG
Min Operating Temperature	-20°F
Max Air Supply Pressure	40 PSIG
Max Ambient Temperature	280°F
Min Ambient Temperature	-20°F

DESIGN PRESSURE/TEMPERATURE RATING – PMA/TMA

NPT	300 PSIG @ 450°F
150# FLG	150 PSIG @ 450°F
300# FLG	300 PSIG @ 450°F



These Control Valve feature all 316 Stainless Steel bodies and trim for use with Steam, Water, Glycol and other chemically compatible fluids.

The **HB Series** is a high performance, general service control valve designed using Computational Fluid Dynamics (CFD) for high control accuracy, optimized flow characteristics and extended service life. These control valves, with stainless steel bodies, are equipped with a contoured plug design to withstand the rigorous nature of steam service and are compatible with many fluids and environments. Modern manufacturing techniques and modular construction allows these stainless steel valves to be extremely cost-effective in comparison to valves with bronze, cast iron or cast steel bodies. The standard configuration has an equal percentage flow characteristic with metal-to-metal seating, spring-loaded Teflon V-ring stem packing and pneumatic actuator. The HB Series is available with both pneumatic or electric actuation.

Description & Operation

A control valve is a device capable of modulating flow at varying degrees between minimal flow and full capacity in response to a signal from an external control device. The valve modulates flow through movement of a valve plug in relation to the port(s) located within the valve body. The valve plug is attached to a valve stem, which, in turn, is connected to the actuator. The actuator, which can be pneumatically or electrically operated, directs the movement of the stem as dictated by the external control device.

Options & Associated Control Loop Accessories

- Electric Actuators
- Positioner: Pneumatic, Electro-Pneumatic or Explosion-Proof
- PID Electronic Controllers (TR890 Series)
- I/P converters (Model TA901)
- Air Filter Regulators (Air Sets-Model TA987)
- Thermocouples
- RTD's
- Pressure Transmitters

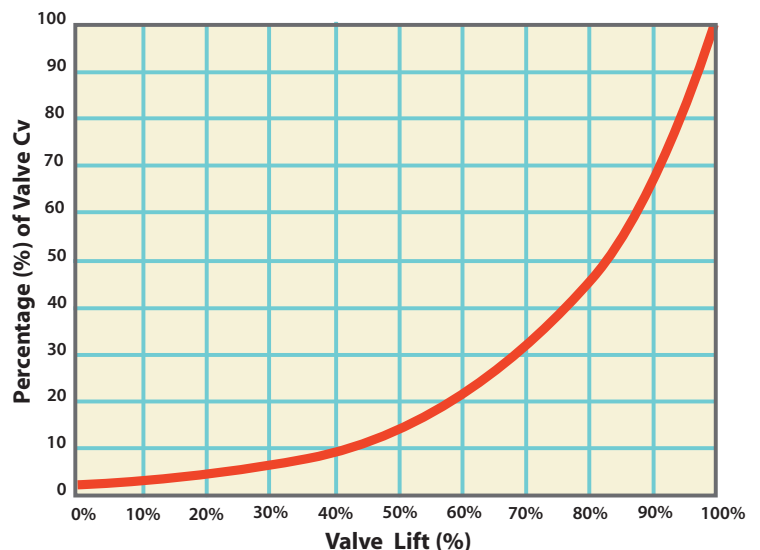

HB Series Control Valve with Pneumatic Actuator

MATERIALS • Pneumatic Actuator		
14	Yoke	Stainless steel
15	Lower actuator stem	Stainless steel
16	Upper diaphragm case	Epoxy painted steel
17	Diaphragm plate	Nickel plated steel
18	Diaphragm*	Nylon reinforced Neoprene
19	Lower diaphragm case	Epoxy painted steel
20	Upper guide bush	SS/Bronze Impregnated
21	Upper actuator stem	Stainless steel
22	Nameplate	Stainless steel
23	Hex nut	Stainless steel
24	Stem O-ring*	Viton
25	Yoke O-ring*	Viton
26	Upper guide O-ring*	Viton
27	Ring nut*	Stainless steel
28	Diaphragm washer	Stainless steel
29	Springs†	Stainless steel
30	Position indicator disc	Stainless steel
33/34	Hex bolt & nut	Grade 5 steel zinc plated

† Air-To-Open Actuator: 6 Actuator Springs

† Air-To-Close Actuator: 3 Actuator Springs

Diaphragm Area = 47 in²

MATERIALS • Valve Body		
1	Stem & Plug Assembly*	Stem: 316 SS, Plug: 303 SS
2	Lower Seal Bushing	303 Stainless Steel
3	Gland Nut	303 Stainless Steel
4	Stem Seal Spring*	302 Stainless Steel
5	Guide Bushing*	Rulon 641
6	Washer	303 Stainless Steel
7	V-ring Stem Seals*	PTFE
8	Body	316 Stainless Steel
10	Body Plug	316 Stainless Steel
11	Body Gasket*	303 Stainless Steel
13	Packing O-Ring	PTFE

* Available as part of a spares kit.

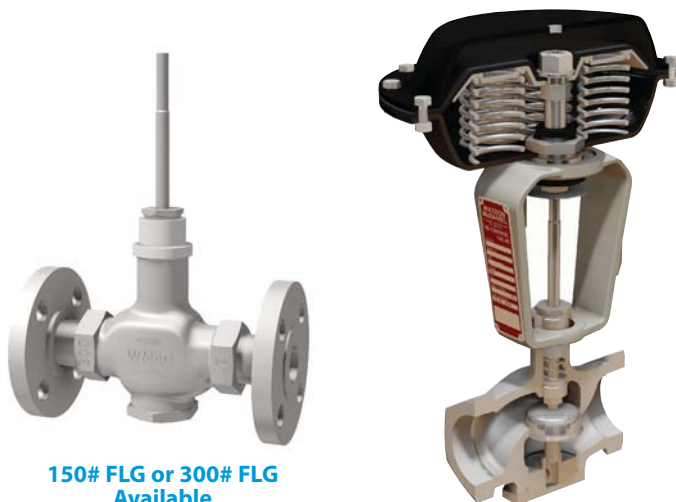
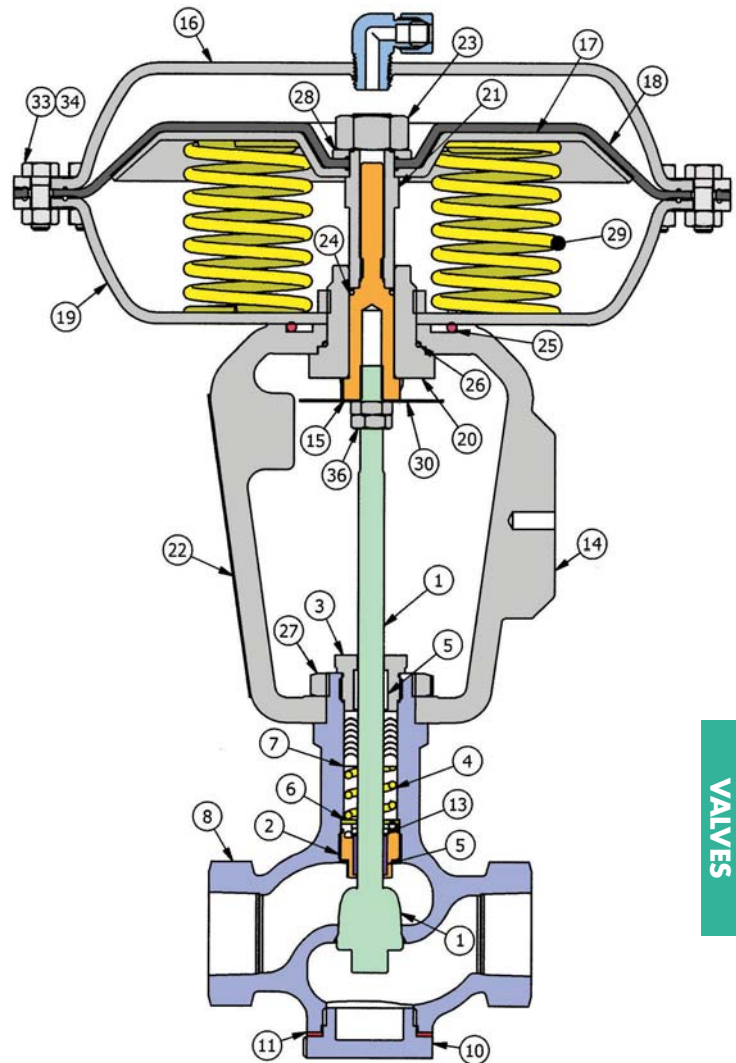

150# FLG or 300# FLG Available

Technical Information	
Plug Design	Contoured
Flow Characteristics	Equal Percentage
Leakage Rating	ANSI/FCI 70-2 Class IV
Rangeability	50:1
Travel	3/4"
Actuator Area	47 sq. in.
Body Design Rating	Class 300
Primary Stem Seals	PTFE Live-Loaded V-Ring
Diaphragm Design	Semi-Rolling
Design	Multi-Spring Diaphragm
Action (field-reversible)	Air-to-Open Air-to-Close
Positioner Mounting	IEC 60534-6-1 (NAMUR)
Stem Wiper	O-Ring

HB Series Control Valve with Pneumatic Actuator

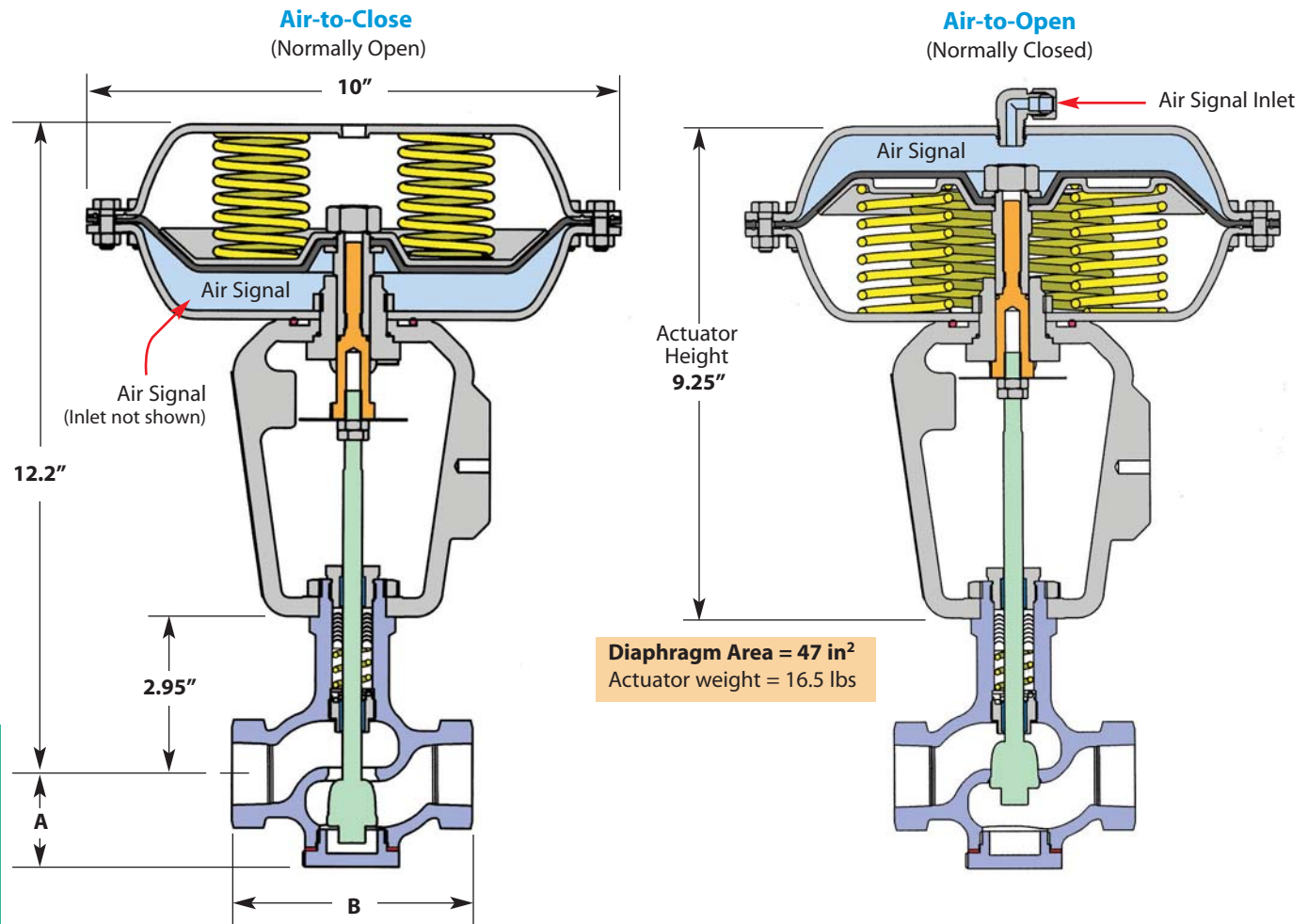

CONTROL VALVES

HB Control Valve Selection

Air-To-CLOSE (Normally OPEN)										
Model HB	Size Connection (NPT)	C _v		Close-Off Pressure (PSI Δ P)		A	NPT B	FLG #150 B	FLG #300 B	Approximate Weight
		Full Port	Reduced Port	No Positioner / Positioner	Positioner					
HB-12-N-ATC	1/2"	5.0	3.5	300	300	1.76	4.5	7.25	7.75	22 lbs [10 kg]
HB-13-N-ATC	3/4"	6.5	3.5	300	300	1.76	4.5	7.25	7.75	22 lbs [10 kg]
HB-14-N-ATC	1"	10	7	300	300	1.74	4.5	7.25	7.75	24 lbs [11 kg]
HB-16-N-ATC	1 1/2"	22	17.5	230	300	2.15	5.0	8.75	9.25	26 lbs [12 kg]
HB-17-N-ATC	2"	42	32	120	300	2.31	6.0	10	10.5	29 lbs [13 kg]

Air-To-OPEN (Normally CLOSED)										
Model HB	Size Connection (NPT)	C _v Full Port	C _v Reduced Port	Close-Off Pressure (PSI Δ P) No Positioner	Close-Off Pressure (PSI Δ P) Positioner	A	NPT B	FLG #150 B	FLG #300 B	Approximate Weight
HB-12-N-ATO	1/2"	5.0	3.5	300	300	1.76	4.5	7.25	7.75	22 lbs [10 kg]
HB-13-N-ATO	3/4"	6.5	3.5	300	300	1.76	4.5	7.25	7.75	22 lbs [10 kg]
HB-14-N-ATO	1"	10	7	300	300	1.74	4.5	7.25	7.75	24 lbs [11 kg]
HB-16-N-ATO	1 1/2"	22	17.5	170	225	2.15	5.0	8.75	9.25	26 lbs [12 kg]
HB-17-N-ATO	2"	42	32	85	135	2.31	6.0	10	10.5	29 lbs [13 kg]

Model Code Configuration Chart

Models	Code	Size	Code	Connection Type	Actuator
HB	Full Port	12 1/2"	N	NPT	ATC Air-to-Close
HBR	Reduced Port	13 3/4"	F150	150# FLG	ATO Air-to-Open
		14 1"	F300	300# FLG	
		16 1 1/2"			
		17 2"			

HB Series Control Valve with Pneumatic Actuator



Type 2000 Valve Positioner (Pneumatic or Electro-Pneumatic)

Type 2000 Valve Positioners (Pneumatic and Electro-Pneumatic) are mechanical devices designed to provide enhanced control, stability, and shut-off capability in extreme flow applications. The positioner, which is mounted to the valve's yoke assembly and linked to the valve stem, receives a signal from an external control source, compares the control signal to the actual position of the valve plug, and then sends a corrected signal to the valve's actuator, thereby positioning the valve plug for optimum flow modulation.



Type-2000	Pneumatic	Electro-Pneumatic
Input Signal	3-15 PSI	4-20 mA
Supply Pressure	145 PSI maximum	21.8 - 145 PSI
Linearity Error	0.7 % full span	<1.0% of full span
Hysteresis	0.4 % full span	<0.6% of full span
Repeatability	0.3 % full span	<0.5% of full span
Pressure Gain	750 P-out/P-in	750 P-out/P-in
Flow Capacity	SCFM	SCFM
@20 PSI	9.5	9.5
@87 PSI	28.3	28.3
@145 PSI	47.1	47.1
Air Consumption	SCFM	SCFM
@20 PSI	0.18	0.2
@87 PSI	0.53	0.6
@145 PSI	0.88	1.0
Impedance		260 Ohms at 70° F
Loop Load		5.2 Volts at 70° F
Port Size	1/4" NPT; Gauge Ports 1/8" NPT	1/2" NPT
Temperature Range	-40° F – 185° F	
Media	Oil-free Instrument Air Filtered to 40 micron	
Enclosure	NEMA 4X	

← **Type 2000 Valve Positioner**
(Pneumatic or Electro-Pneumatic)

Valve Positioner Model Code Configuration

Example Model : CA2000L1C3N

Model	Positioner Type	Indicator	Code
CA2000L1C3	Pneumatic	None (Standard Linear)	N
CA2010L1C3	Electro-Pneumatic	Dome (Option)	D
CA2020L1C3	Explosion-Proof		