

Model	TD600, TD600L
Sizes	3/8", 1/2", 3/4", 1"
Connections	NPT
Body Material	Stainless Steel 420F
Options	Insulation Cap
PMO Max. Operating Pressure	600 PSIG
TMO Max. Operating Temperature	800°F
PMA Max. Allowable Pressure	600 PSIG up to 800°F
TMA Max. Allowable Temperature	800°F @ 600 PSIG



Typical Applications

DRIP, TRACING: TD600 model steam traps are most commonly used in drip applications, such as draining condensate from steam mains and steam supply lines. They can also be used for steam tracing applications. These traps are suitable for outdoor applications that are subject to freezing as well as superheated steam conditions. They are compact and rugged with only a single moving part. If a trap with an integral strainer is desired, the TD600S is recommended. If a fully in-line repairable design is required, the TD700S or the UTD450 with Universal Quick-Change connector is recommended.

How It Works

The disc is the only moving part inside a thermodynamic trap. When steam enters the trap, it creates an internal pressure above the disc that instantly forces the disc to close tightly on the seat, preventing the steam from escaping. The internal steam pressure (holding the disc and seat shut) eventually drops, and the trap re-opens. When condensate enters the trap, it pushes the disc upwards, allowing the condensate to freely discharge. If steam is present, the trap instantly shuts.

Features

- High pressure applications up to 600 PSIG
- Hardened stainless steel seat and disc for extended service life even at high pressure
- Single trap will operate over the entire pressure range of 3.5-600 PSIG (recommended above 30 PSIG)
- Suitable for superheated steam
- Freeze-proof when trap is piped in a vertical orientation for complete drainage of condensate
- Three-hole balanced discharge extends life of the seat area
- Trap will function in any orientation (horizontal preferred)

Sample Specification

The steam trap shall be a thermodynamic disc type with all stainless steel construction. Integral seat design and disc to be hardened for long service life. Unit shall be capable of installation in any orientation and self-draining when mounted vertically.

Installation and Maintenance

The TD600 can be installed in any orientation; however, horizontal with cap facing upward is preferred for longest service life. The one piece body-seat design is extremely simple and economical; however, this configuration is generally considered not fully repairable since the seat cannot be repaired if damaged or worn. Welding of trap body directly into pipeline is not recommended since excessive heat may cause distortion of the seat area. The TD600 does not contain an integral strainer and separate strainer should therefore be installed to protect from dirt and pipe scale. If a fully in-line repairable design or a trap that can be welded into pipeline is desired, the TD700S, TD900S or the UTD450 with Universal Quick-Change connector is recommended.

Helpful Selection Information

The TD600L has reduced size discharge orifice holes which are preferable in terms of performance, longevity, and efficiency; particularly on pressures over 150 psi. For most drip applications the 1/2" TD600L should have sufficient capacity. For higher load drip applications or if a 3/4" pipe connection is required, use 3/4" TD600L for best results. Choosing a model with a condensate handling capacity in the range of the specific application will prolong trap life.

L = Reduced Size Discharge Orifice holes which are preferable in terms of performance, longevity, and efficiency; particularly on pressures over 150 psi.

Options

An insulation cap is available to reduce cycle rates and steam loss in rain, snow, or cold environments.

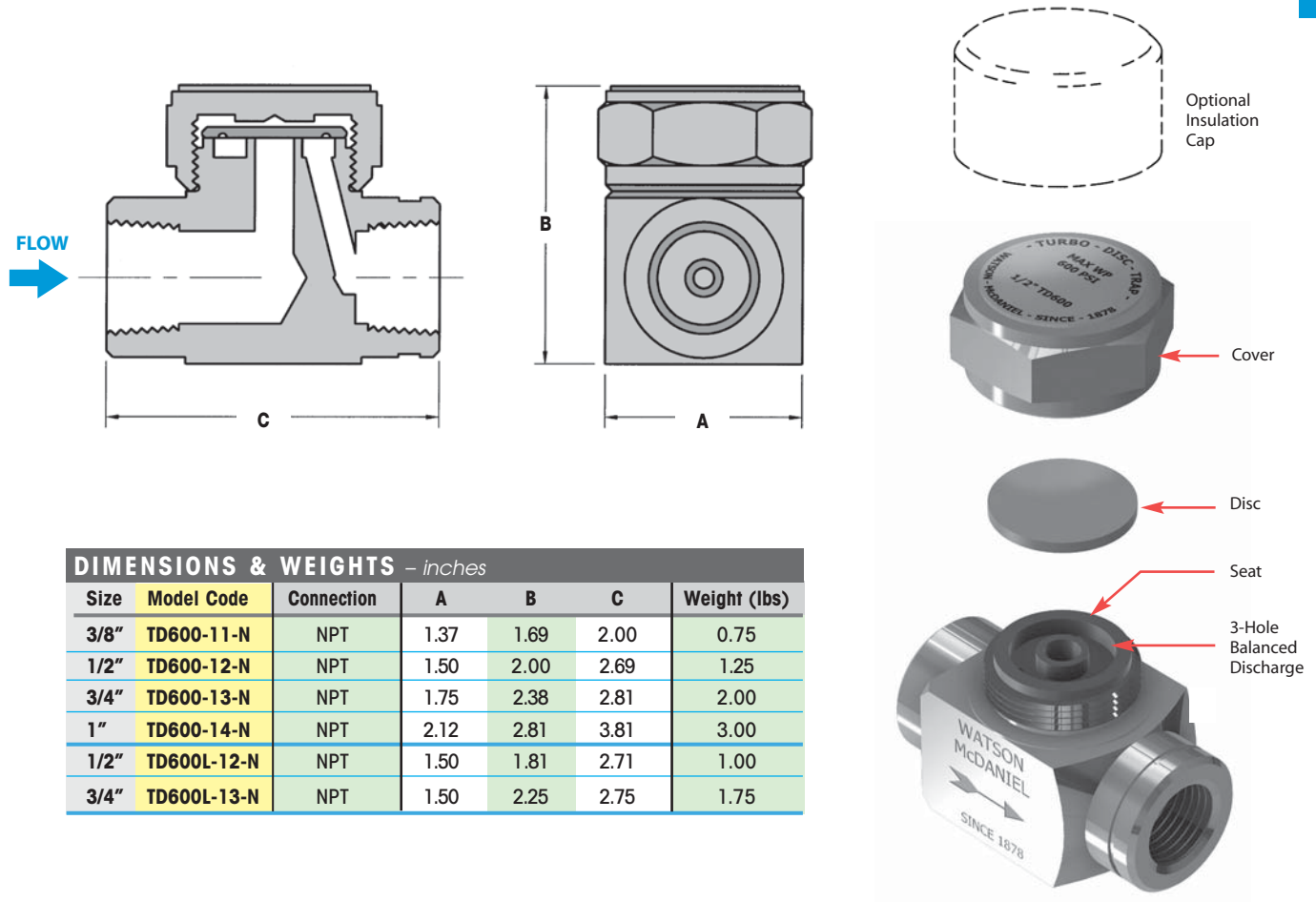

DIMENSIONS & WEIGHTS – inches						
Size	Model Code	Connection	A	B	C	Weight (lbs)
3/8"	TD600-11-N	NPT	1.37	1.69	2.00	0.75
1/2"	TD600-12-N	NPT	1.50	2.00	2.69	1.25
3/4"	TD600-13-N	NPT	1.75	2.38	2.81	2.00
1"	TD600-14-N	NPT	2.12	2.81	3.81	3.00
1/2"	TD600L-12-N	NPT	1.50	1.81	2.71	1.00
3/4"	TD600L-13-N	NPT	1.50	2.25	2.75	1.75

How to Size / Order

Select working pressure; follow column down to correct capacity (lbs/hr) block. Example:

Application: 500 lbs/hr at 100 PSIG working inlet pressure

Size/Model: 3/4" TD600L-13-N

MATERIALS

Body	Stainless Steel, AISI 420F
Disc	Stainless Steel, AISI 420
Cover	Stainless Steel, AISI 416
Insulation Cap	Stainless Steel, AISI 304

CAPACITIES – Condensate (lbs/hr)

Size	Model Code	Steam Inlet Pressure (PSIG)																				
		3.5	5	10	15	20	25	30	40	50	75	100	150	200	250	300	350	400	450	500	550	600
1/2"	TD600L-12-N	180	185	190	195	200	215	220	230	250	310	375	500	620	710	800	825	900	1070	1120	1185	1290
3/4"	TD600L-13-N	300	315	350	380	415	440	470	515	580	710	825	1020	1165	1300	1440	1565	1670	1775	1880	1960	2060
3/8"	TD600-11-N	180	185	190	195	200	215	220	230	250	310	375	500	620	710	800	825	900	1070	1120	1185	1290
1/2"	TD600-12-N	300	315	350	380	415	440	470	515	580	710	825	1020	1165	1300	1440	1565	1670	1775	1880	1960	2060
3/4"	TD600-13-N	415	430	475	520	565	610	650	720	825	1020	1185	1480	1710	1950	2110	2265	2490	2625	2780	2985	3140
1"	TD600-14-N	650	680	740	815	885	940	1000	1080	1225	1500	1800	2215	2625	2935	3300	3600	3875	4120	4350	4560	4840

Notes: 1) Maximum back pressure not to exceed 80% of inlet pressure (measured in absolute pressure) or trap may not close.
 2) For optimum performance, recommended for operating pressure above 30 PSIG.

Steam Traps

Thermodynamic Steam Trap

TD600S

Thermodynamic

Model	TD600S, TD600LS
Sizes	1/2", 3/4", 1"
Connections	NPT
Body Material	Stainless Steel 420F
Options	Blowdown Valve, Insulation Cap
PMO Max. Operating Pressure	600 PSIG
TMO Max. Operating Temperature	750°F
PMA Max. Allowable Pressure	915 PSIG up to 250°F
TMA Max. Allowable Temperature	610°F @ 750 PSIG



TD600S
Strainer



TD600SB
Strainer &
Blowdown Valve

Typical Applications

DRIP, TRACING: TD600S model steam traps with integral strainer are most commonly used in drip applications, such as draining condensate from steam mains and steam supply lines. They can also be used for steam tracing applications. These traps are suitable for outdoor applications that are subject to freezing as well as superheated steam conditions. They are compact and rugged with only a single moving part. Integral strainer protects against dirt and scale. If a fully in-line repairable design is required, the TD700S or the UTD450 with Universal Quick-Change Connector is recommended.

How It Works

The disc is the only moving part inside a thermodynamic trap. When steam enters the trap, it creates an internal pressure above the disc that instantly forces the disc to close tightly on the seat, preventing the steam from escaping. The internal steam pressure (holding the disc and seat shut) eventually drops, and the trap re-opens. When condensate enters the trap, it pushes the disc upwards, allowing the condensate to freely discharge. If steam is present, the trap instantly shuts.

Features

- Integral strainer with optional blowdown valve to protect trap from contamination
- High pressure applications up to 600 PSIG
- Hardened stainless steel seat and disc for extended service life even at high pressure
- Single trap will operate over the entire pressure range of 3.5-600 PSIG (recommended above 30 PSIG)
- Suitable for superheated steam
- Freeze-proof when trap is piped in a vertical orientation for complete drainage of condensate
- Three-hole balanced discharge extends life of the seat area
- Trap will function in any orientation (horizontal preferred)

Sample Specification

The steam trap shall be all stainless steel thermodynamic type with hardened integral seat and disc with integral strainer and blowdown valve.

Installation and Maintenance

The TD600S can be installed in any orientation; however, horizontal with cap facing upward is preferred for longest service life. The one piece body-seat design is extremely simple and economical; however, this configuration is generally considered not fully repairable since the seat cannot be replaced if damaged or worn. Welding of trap body directly into pipeline is not recommended since excessive heat can cause distortion of the seat area. All models of the TD600S contain an integral strainer for protection against dirt and scale. If a fully in-line repairable design or a trap that can be welded into pipeline is desired, the TD700S, TD900S or the UTD450 with Universal Quick-Change connectors is recommended.

Helpful Selection Information

The TD600LS has reduced size discharge orifice holes which are preferable in terms of performance, longevity, and efficiency; particularly on pressures over 150 psi. For most drip applications the 1/2" TD600LS should have sufficient capacity. For higher load drip applications or if a 3/4" pipe connection is required, use 3/4" TD600LS for best results. Choosing a model with a condensate handling capacity in the range of the specific application will prolong trap life.

L = Reduced Size Discharge Orifice holes which are preferable in terms of performance, longevity, and efficiency; particularly on pressures over 150 psi.

Options

An insulation cap is available to reduce cycle rates and steam loss in rain, snow, or cold environments. Blowdown valve, used for flushing dirt and scale from strainer.

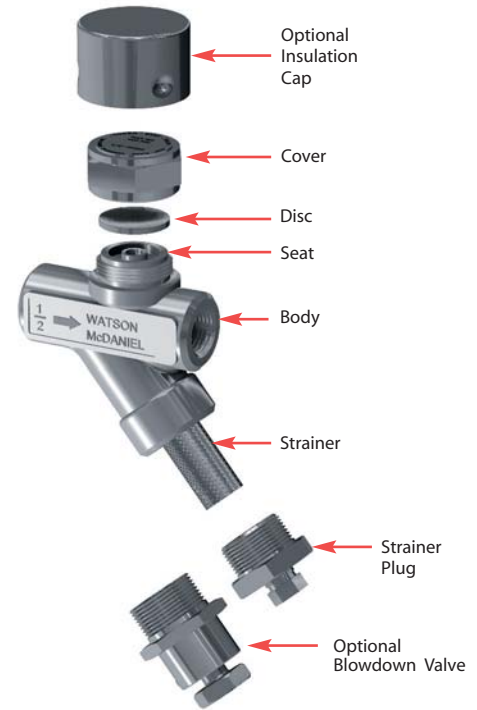
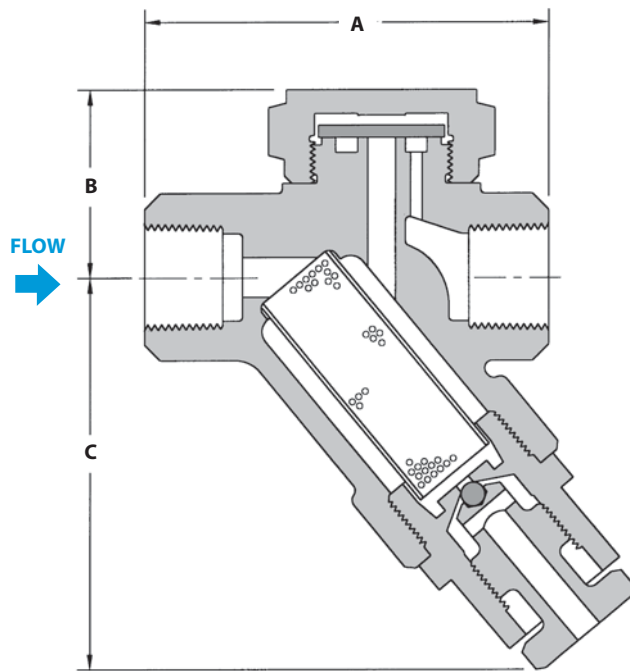

DIMENSIONS & WEIGHTS – inches						
Size	Model	Conn.	A	B	C	Weight (lbs)
Series TD600S (Strainer)						
1/2"	TD600S-12-N	NPT	3.16	1.50	2.53	2
1/2"	TD600LS-12-N	NPT	3.16	1.44	2.53	1.5
3/4"	TD600S-13-N	NPT	3.56	1.62	2.53	2.5
3/4"	TD600LS-13-N	NPT	3.56	1.56	2.53	2.4
1"	TD600LS-13-N	NPT	3.75	1.44	2.53	2.5

Series TD600SB (Strainer & Blowdown Valve)						
Size	Model	Conn.	A	B	C	Weight (lbs)
1/2"	TD600SB-12-N	NPT	3.16	1.50	3.5	2.3
1/2"	TD600LSB-12-N	NPT	3.16	1.44	3.5	2.0
3/4"	TD600SB-13-N	NPT	3.56	1.62	3.5	2.8
3/4"	TD600LSB-13-N	NPT	3.56	1.56	3.5	2.7
1"	TD600LSB-14-N	NPT	3.72	1.44	3.5	2.7

MATERIALS	
Body	Stainless Steel, AISI 420F
Disc	Stainless Steel, AISI 420
Cover	Stainless Steel, AISI 416
Insulation Cap	Stainless Steel, AISI 304
Strainer Screen	Stainless Steel, AISI 304
Blowdown Valve	Stainless Steel, AISI 303

How to Size / Order
 Select working pressure; follow column down to correct capacity (lbs/hr) block. Example:
 Application: 500 lbs/hr at 100 PSIG working inlet pressure
 Size/Model: 3/4" **TD600LS-13-N**

CAPACITIES – Condensate (lbs/hr)		Steam Inlet Pressure (PSIG)																			
Size	Model	3.5	5	10	15	20	25	30	40	50	75	100	150	200	250	300	400	450	500	550	600
1/2"	TD600LS-12-N	180	185	190	195	200	215	220	230	250	310	375	500	620	710	800	900	1070	1120	1185	1290
1"	TD600LS-14-N																				
3/4"	TD600LS-13-N	300	315	350	380	415	440	470	515	580	710	825	1020	1165	1300	1440	1670	1775	1880	1960	2060
1/2"	TD600S-12-N	300	315	350	380	415	440	470	515	580	710	825	1020	1165	1300	1440	1670	1775	1880	1960	2060
3/4"	TD600S-13-N	415	430	475	520	565	610	650	720	825	1020	1185	1480	1710	1950	2110	2265	2625	2780	2985	3140

Note: Maximum back pressure not to exceed 80% of inlet pressure (measured in absolute pressure) or trap may not close.
Note: For optimum performance, recommended for operating pressure above 30 PSIG.